

共通规格	
精度等级	JIS N9级 (JIS B 1702-1 : 1998) *
齿形	全齿高齿
压力角	20°
材料	MC602ST(轮毂部为 S45C)
热处理	—
齿面硬度	(115 ~ 120HRR)

* J系列产品的精度相当于表记精度。

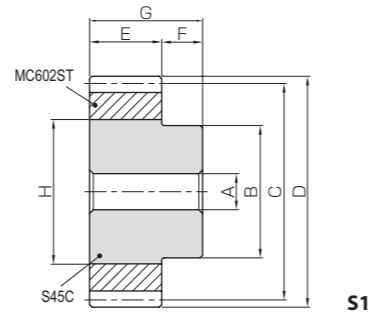

S1

J系列

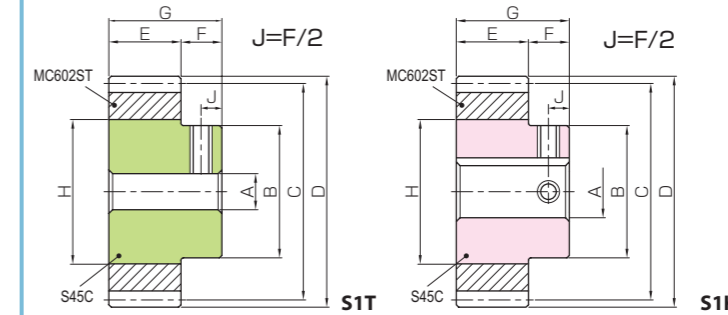

S1K

J系列产品型号为标准品型号 + J + 孔径

孔径 H7	*表中颜色与 J 系列形状图的截面颜色相对应。																			
	8	10	12	14	15	16	17	18	19	20	22	25	28	30	32	35				
键槽 Js9	—																			
螺孔尺寸	4 × 1.8				5 × 2.3				6 × 2.8				8 × 3.3				10 × 3.3			
产品型号	M5		M4						M5				M6				M8			
NSU1-30 J 孔径	S1T																			
NSU1-32 J 孔径	S1T	S1K																		
NSU1-35 J 孔径	S1T	S1K	S1K																	
NSU1-36 J 孔径	S1T	S1K	S1K																	
NSU1-40 J 孔径		S1K	S1K																	
NSU1-45 J 孔径		S1K	S1K	S1K	S1K	S1K	S1K													
NSU1-48 J 孔径		S1K	S1K	S1K	S1K	S1K	S1K													
NSU1-50 J 孔径		S1K	S1K	S1K	S1K	S1K	S1K													
NSU1-60 J 孔径		S1K	S1K	S1K	S1K	S1K	S1K	S1K	S1K	S1K	S1K									
NSU1-70 J 孔径		S1K	S1K	S1K	S1K	S1K	S1K	S1K	S1K	S1K	S1K	S1K	S1K							
NSU1-80 J 孔径		S1K	S1K	S1K	S1K	S1K	S1K	S1K	S1K	S1K	S1K	S1K	S1K	S1K						
NSU1-90 J 孔径		S1K	S1K	S1K	S1K	S1K	S1K	S1K	S1K	S1K	S1K	S1K	S1K	S1K	S1K					
NSU1-100 J 孔径		S1K	S1K	S1K	S1K	S1K	S1K	S1K	S1K	S1K	S1K	S1K	S1K	S1K	S1K	S1K				
NSU1.5-28 J 孔径		S1K	S1K	S1K	S1K	S1K	S1K													
NSU1.5-30 J 孔径		S1K	S1K	S1K	S1K	S1K	S1K													
NSU1.5-32 J 孔径		S1K	S1K	S1K	S1K	S1K	S1K													
NSU1.5-35 J 孔径		S1K	S1K	S1K	S1K	S1K	S1K													
NSU1.5-36 J 孔径		S1K	S1K	S1K	S1K	S1K	S1K													
NSU1.5-40 J 孔径		S1K	S1K	S1K	S1K	S1K	S1K	S1K	S1K	S1K	S1K									
NSU1.5-45 J 孔径		S1K	S1K	S1K	S1K	S1K	S1K	S1K	S1K	S1K	S1K	S1K	S1K							
NSU1.5-48 J 孔径		S1K	S1K	S1K	S1K	S1K	S1K	S1K	S1K	S1K	S1K	S1K	S1K	S1K						
NSU1.5-50 J 孔径			S1K	S1K	S1K	S1K	S1K	S1K	S1K	S1K	S1K	S1K	S1K	S1K	S1K					
NSU1.5-56 J 孔径			S1K	S1K	S1K	S1K	S1K	S1K	S1K	S1K	S1K	S1K	S1K	S1K	S1K	S1K	S1K			
NSU1.5-60 J 孔径			S1K	S1K	S1K	S1K	S1K	S1K	S1K	S1K	S1K	S1K	S1K	S1K	S1K	S1K	S1K	S1K		
NSU1.5-70 J 孔径			S1K	S1K	S1K	S1K	S1K	S1K	S1K	S1K	S1K	S1K	S1K	S1K	S1K	S1K	S1K	S1K	S1K	
NSU1.5-80 J 孔径			S1K	S1K	S1K	S1K	S1K	S1K	S1K	S1K	S1K	S1K	S1K	S1K	S1K	S1K	S1K	S1K	S1K	
NSU1.5-90 J 孔径			S1K	S1K	S1K	S1K	S1K	S1K	S1K	S1K	S1K	S1K	S1K	S1K	S1K	S1K	S1K	S1K	S1K	
NSU2-20 J 孔径		S1K																		
NSU2-22 J 孔径		S1K	S1K	S1K	S1K	S1K	S1K													
NSU2-24 J 孔径		S1K	S1K	S1K	S1K	S1K	S1K													
NSU2-25 J 孔径		S1K	S1K	S1K	S1K	S1K	S1K													
NSU2-28 J 孔径		S1K	S1K	S1K	S1K	S1K	S1K	S1K	S1K											
NSU2-30 J 孔径		S1K	S1K	S1K	S1K	S1K	S1K	S1K	S1K											
NSU2-32 J 孔径			S1K	S1K	S1K	S1K	S1K	S1K	S1K	S1K	S1K									
NSU2-35 J 孔径			S1K	S1K	S1K	S1K	S1K	S1K	S1K	S1K	S1K	S1K	S1K							
NSU2-36 J 孔径			S1K	S1K	S1K	S1K	S1K	S1K	S1K	S1K	S1K	S1K	S1K	S1K						
NSU2-40 J 孔径					S1K	S1K	S1K	S1K	S1K	S1K	S1K	S1K	S1K	S1K	S1K	S1K	S1K			
NSU2-44 J 孔径					S1K	S1K	S1K	S1K	S1K	S1K	S1K	S1K	S1K	S1K	S1K	S1K	S1K	S1K		
NSU2-45 J 孔径					S1K	S1K	S1K	S1K	S1K	S1K	S1K	S1K	S1K	S1K	S1K	S1K	S1K	S1K	S1K	
NSU2-48 J 孔径					S1K	S1K	S1K	S1K	S1K	S1K	S1K	S1K	S1K	S1K	S1K	S1K	S1K	S1K	S1K	
NSU2-50 J 孔径					S1K	S1K	S1K	S1K	S1K	S1K	S1K	S1K	S1K	S1K	S1K	S1K	S1K	S1K	S1K	
NSU2-56 J 孔径					S1K	S1K	S1K	S1K	S1K	S1K	S1K	S1K	S1K	S1K	S1K	S1K	S1K	S1K	S1K	
NSU2-60 J 孔径					S1K	S1K	S1K	S1K	S1K	S1K	S1K	S1K	S1K	S1K	S1K	S1K	S1K	S1K	S1K	
NSU2-70 J 孔径					S1K	S1K	S1K	S1K	S1K	S1K	S1K	S1K	S1K	S1K	S1K	S1K	S1K	S1K	S1K	
NSU2-80 J 孔径					S1K	S1K	S1K	S1K	S1K	S1K	S1K	S1K	S1K	S1K	S1K	S1K	S1K	S1K	S1K	

直齿轮

斜齿轮

内齿轮

齿条

& C P 小齿轮

等径锥齿轮

锥齿轮

交错轴斜齿轮

蜗轮蜗杆

齿轮箱

其他产品

直齿轮

斜齿轮

内齿轮

齿条

& C P 小齿轮

等径锥齿轮

锥齿轮

交错轴斜齿轮

蜗轮蜗杆

齿轮箱

其他产品

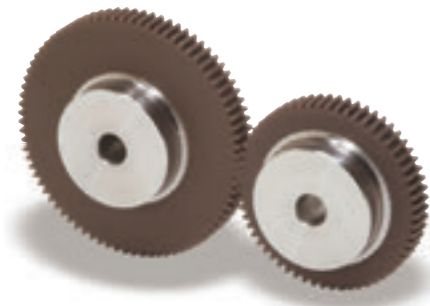

共通规格	
精度等级	JIS N9级 (JIS B 1702-1 : 1998) *
齿形	全齿高齿
压力角	20°
材料	MC602ST(轮毂部为 S45C)
热处理	—
齿面硬度	(115 ~ 120HRR)

* J系列产品的精度相当于表记精度。

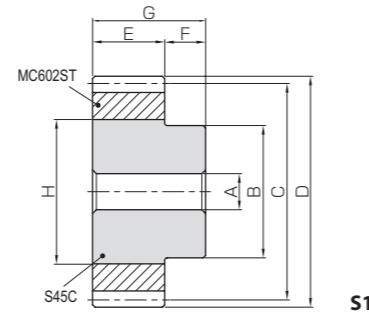

S1

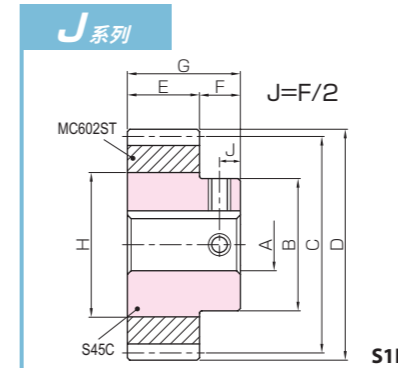

S1K



J系列产品型号为标准品型号 + J + 孔径

*表中颜色与J系列形状图的截面颜色相对应。

孔径 H7	*表中颜色与J系列形状图的截面颜色相对应。																			
键槽 Js9	12	14	15	16	17	18	19	20	22	25	28	30	32	35	40					
螺孔尺寸	4 × 1.8				5 × 2.3				6 × 2.8				8 × 3.3				10 × 3.3	12 × 3.3		
产品型号	M4								M5				M6				M8			
NSU2.5-18 J 孔径	S1K																			
NSU2.5-20 J 孔径	S1K	S1K	S1K																	
NSU2.5-22 J 孔径	S1K	S1K	S1K	S1K	S1K	S1K	S1K													
NSU2.5-24 J 孔径	S1K	S1K	S1K	S1K	S1K	S1K	S1K													
NSU2.5-25 J 孔径	S1K	S1K	S1K	S1K	S1K	S1K	S1K													
NSU2.5-28 J 孔径	S1K	S1K	S1K	S1K	S1K	S1K	S1K	S1K	S1K											
NSU2.5-30 J 孔径	S1K	S1K	S1K	S1K	S1K	S1K	S1K	S1K	S1K	S1K										
NSU2.5-32 J 孔径	S1K	S1K	S1K	S1K	S1K	S1K	S1K	S1K	S1K	S1K	S1K									
NSU2.5-35 J 孔径	S1K	S1K	S1K	S1K	S1K	S1K	S1K	S1K	S1K	S1K	S1K	S1K	S1K	S1K						
NSU2.5-36 J 孔径	S1K	S1K	S1K	S1K	S1K	S1K	S1K	S1K	S1K	S1K	S1K	S1K	S1K	S1K						
NSU2.5-40 J 孔径			S1K	S1K	S1K	S1K	S1K	S1K	S1K	S1K	S1K	S1K	S1K	S1K	S1K					
NSU2.5-44 J 孔径			S1K	S1K	S1K	S1K	S1K	S1K	S1K	S1K	S1K	S1K	S1K	S1K	S1K					
NSU2.5-45 J 孔径			S1K	S1K	S1K	S1K	S1K	S1K	S1K	S1K	S1K	S1K	S1K	S1K	S1K					
NSU2.5-48 J 孔径			S1K	S1K	S1K	S1K	S1K	S1K	S1K	S1K	S1K	S1K	S1K	S1K	S1K					
NSU2.5-50 J 孔径			S1K	S1K	S1K	S1K	S1K	S1K	S1K	S1K	S1K	S1K	S1K	S1K	S1K					
NSU2.5-56 J 孔径			S1K	S1K	S1K	S1K	S1K	S1K	S1K	S1K	S1K	S1K	S1K	S1K	S1K					
NSU2.5-60 J 孔径								S1K	S1K	S1K	S1K	S1K	S1K	S1K	S1K					
NSU2.5-70 J 孔径									S1K	S1K	S1K	S1K	S1K	S1K	S1K					
NSU3-20 J 孔径	S1K	S1K	S1K	S1K	S1K															
NSU3-22 J 孔径	S1K	S1K	S1K	S1K	S1K	S1K	S1K	S1K	S1K											
NSU3-24 J 孔径	S1K	S1K	S1K	S1K	S1K	S1K	S1K	S1K	S1K											
NSU3-25 J 孔径	S1K	S1K	S1K	S1K	S1K	S1K	S1K	S1K	S1K	S1K										
NSU3-28 J 孔径			S1K	S1K	S1K	S1K	S1K	S1K	S1K	S1K	S1K									
NSU3-30 J 孔径			S1K	S1K	S1K	S1K	S1K	S1K	S1K	S1K	S1K	S1K								
NSU3-32 J 孔径			S1K	S1K	S1K	S1K	S1K	S1K	S1K	S1K	S1K	S1K	S1K							
NSU3-34 J 孔径			S1K	S1K	S1K	S1K	S1K	S1K	S1K	S1K	S1K	S1K	S1K	S1K						
NSU3-35 J 孔径			S1K	S1K	S1K	S1K	S1K	S1K	S1K	S1K	S1K	S1K	S1K	S1K						
NSU3-36 J 孔径			S1K	S1K	S1K	S1K	S1K	S1K	S1K	S1K	S1K	S1K	S1K	S1K						
NSU3-40 J 孔径										S1K	S1K	S1K	S1K	S1K	S1K					
NSU3-44 J 孔径										S1K	S1K	S1K	S1K	S1K	S1K					
NSU3-45 J 孔径										S1K	S1K	S1K	S1K	S1K	S1K					
NSU3-48 J 孔径										S1K	S1K	S1K	S1K	S1K	S1K					
NSU3-50 J 孔径										S1K	S1K	S1K	S1K	S1K	S1K					
NSU3-56 J 孔径										S1K	S1K	S1K	S1K	S1K	S1K					
NSU3-60 J 孔径										S1K	S1K	S1K	S1K	S1K	S1K					
NSU3-68 J 孔径										S1K	S1K	S1K	S1K	S1K	S1K					
NSU3-70 J 孔径										S1K	S1K	S1K	S1K	S1K	S1K					

直齿轮

斜齿轮

内齿轮

齿条

& C P 小齿条

等径锥齿轮

锥齿轮

交错轴斜齿轮

蜗轮蜗杆

齿轮箱

其他产品

直齿轮

斜齿轮

内齿轮

齿条

& C P 小齿条

等径锥齿轮

锥齿轮

交错轴斜齿轮

蜗轮蜗杆

齿轮箱

其他产品